



JETPT40-P3-V2 (DVTR285R2S)

Features

- Operating case temperature -60 ... +125 °C
- Efficiency up to 85 %
- Case dimensions: 73.4 x 28.6 x 10.3 (mm)
- Input "27W" (15-50 VDC)
- Remote off
- Replaces VPT unit **DVTR285R2S**
- **VERSION 2**, with reversed cooling surface

Description

JETPT40 series of DC/DC isolated converters is **an analogue replacement of DVTR285R2S series**. The combination of electro-technical and mechanical parameters creates versatility for the series to be used in various application fields: both low and high altitude in unprotected equipment compartments, in all types of transport, in supercomputers, in low and high temperature environments, digital signage equipment, in radar systems. The series is an optimal fit for any environment which requires low-profile, minimized dimensions and weight, high efficiency and wide temperature range.

VERSION 2, Input "27W", one channel, DVTR285R2S repl.					
Model part number	Input voltage	Output power	Output voltage	Output current per channel	Typical efficiency at 70 % load
JETPT40-27WS5.2-P3-V2 (DVTR285R2S)	15-50 VDC (27 VDC nom.) 80 VDC 1s transient	31.2 W	5.2 VDC	6.00 A	85 %

JETPT40-P3-V2 (DVTR285R2S)

General characteristics ³		
Switching frequency		330 kHz typ. (PWM modulation)
Temperature ranges	case operating temperature	-60° C ... +125° C
	storage temperature	-60° C ... +125° C
Over-temperature protection		+125° C typ.
Thermal mode and cooling method	cooling methods, from most preferred (for the unit to be used with a coldplate or heatsink it's necessary to consult with the producer)	1. Conductive - heatsink-coldplate. 2. Forced air heatsink cooler. 3. Convectional heatsink cooling with vertical orientation of itself and vertical orientation of its ribs for free air flow from bottom to top. 4. Without a heatsink - with means of natural convection.
Humidity (non-condensing)		5-95 % rel. H
Insulation	in/case, in/out	1500 VDC
	out/case	1000 VDC
	out/out	<i>not isolated</i>
Isolating resistance @ 500 VDC		>20 MOhm
Thermal shock, mechanical shock & vibration		MIL-STD-810F
Safety standards		IEC/EN 60950-1
Typical MTBF	Pout = 0.7·Pout,max	190 000 hrs (Tcase = 50° C)
Weight (max)		60 g
Input characteristics ³		
Input voltage range (with power derating)	"27W"	15-50 VDC, 27 VDC nom., 80 VDC 1s transient
Start-up input voltage	for "27W" input	typ. 14 VDC
Output characteristics ³		
Power derating based on input voltage	-	no derating
Output voltage adjustment	+10 % via +S output	
Output voltage regulation for main channel (+VOUT)	input variance Uin,min to Uin,max	±0.5 % for load 10-100 %
	load variance 10 % to 100 %	±1 %
Ripple and noise (peak-to-peak)	20 MHz bandwidth	<1 % for load 10-100 %
Protection	over-current	auto-reset at 110-150 % of Iout,nom
	over-voltage	<130 % Uout
Remote OFF	connect INHIBIT to -IN	

Additional ordering information:

- 1) See available filters on www.aeps-group.com.
- 2) When varying load in the main stabilized channel from 10 % to 100 %, secondary output voltage regulation may reach ±13 %
- 3) All specifications are valid for normal climatic conditions, nominal output voltage and current, unless stated otherwise.

Power-temperature relationship

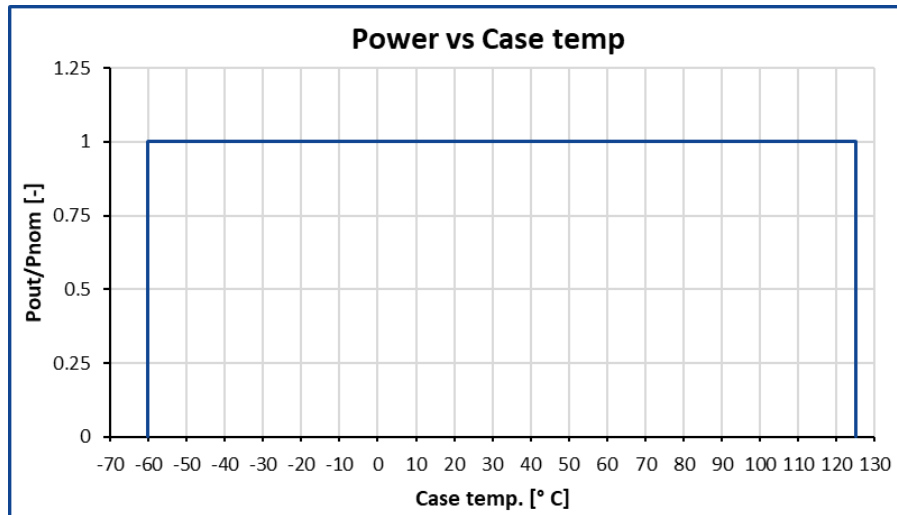

Additional application information

1. Value of case temperature

The case temperature is measured at the middle of the long side of the case base. When using a thermocouple, it is necessary to fixate the conductors (connected to the thermocouple end) to the base surface at a distance of at least 20 mm. The thermocouple measuring end and its conductors must be covered with a layer of heat-conducting paste 2-3 mm thick to provide correct measurements.

2. Possible cooling methods

- 1) Conductive cooling with aluminum (or copper) **heatsink-coldplate**, for example, aluminum plate thicker than 1 mm.
- 2) Forced air.
- 3) Convective heatsink cooling with vertical orientation of itself and vertical orientation of its ribs for free air flow from bottom to top.
- 4) Without a heatsink via means of natural convection. In such case it's assumed that the unit is mounted on a vertically positioned PCB, which doesn't contain any other significant heat sources. In any case - it's necessary to provide un-constricted airflow around the unit. **To use the units without a heatsink it's recommended to consult with the producer.**

Most of the unit's dissipated heat (93-95 %) is concentrated on the top surface of the unit, its base, which must be attached to the heatsink-coldplate or ribbed heatsink surface. Requirements for the heatsink surface (preferably CNC milled) - flatness tolerance of the heatsink surface must be lower than 0.1 mm per 100 mm of length.

3. Unit heatsink fixation

If 4 mounting holes are available, then first one pair of diagonally located holes is connected with screws, then a second pair. First installation of the screws should be done without force. Then all the screws should be tightened with the recommended torque.

For quality contact between the unit and a heatsink - it's necessary to use thermal conductive paste with thickness less than 0.1 mm, with thermal conductivity **greater than 5 W/K.m**. The paste must be applied with mesh stencil in a pattern of squares (i.e. 2x2 mm to 4x4 mm squares mm with 0.5-1 mm spacing between the squares). This allows paste to be evenly spread in a thin layer and excess air to escape when tightening screws during unit mounting.

4. Short-term unit operation

If it's necessary to shortly turn on the unit for 3-5 minutes (for example for input-control testing), an aluminum (copper) coldplate must be used as a heatsink. Its width and length must be not less than of the unit itself, with thickness at least 2 mm. The unit must be placed on coldplate through a thin (0.15-0.3 mm) silicone-based heat-conducting sheet.

5. MTBF dependence on case temperature

When using the unit, a customer must in one way or another monitor maximal heatsink temperature. Maximal heatsink temperature near the center point of the longer unit's side (considered as unit case temperature) must correspond to the expected unit's MTBF. Approximate MTBF function shown on the graph lower, where $MTBF / MTBF_{50}$ is unit's MTBF value at chosen unit's case operating temperature relative to value at 50°C unit's case temperature. Maximal unit's case temperature is recorded by internal unit's thermal sensor-monitor.

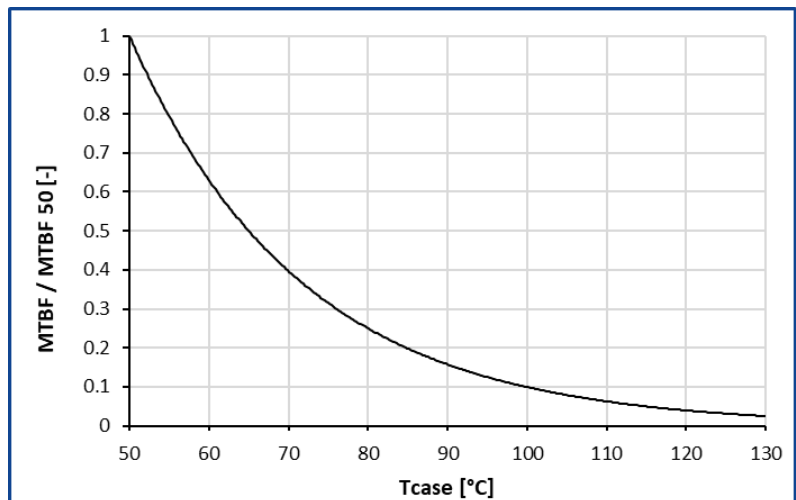

6. Thermal protection tripping

When internal unit's thermal protection is tripped (typ. +125 °C) the unit is turned off (until automatic restart). **Such state should lead to measures of forced heatsink cooling, for example via fans turn-on.** Time before automatic restart of the unit after thermal protection tripping can last from several seconds up to several minutes depending on thermal inertia of the heatsink.

7. Operation with shorted outputs

The units have a short-circuit output protection. **The protection is for emergency only, not for long-term operation. It's prohibited to use the units with shorted outputs (the units have the special detectors inside).**

8. Output voltage trimming

The output voltage can be increased by connecting a resistor RTR between +S (pin 6) and OUTCOM (pin 4). Maximum trimming range is +10%. Application schematics and approximate trimming resistor values to achieve output voltage adjustment are given in the table below. -S (pin 3) should be connected to OUTCOM (pin 4).

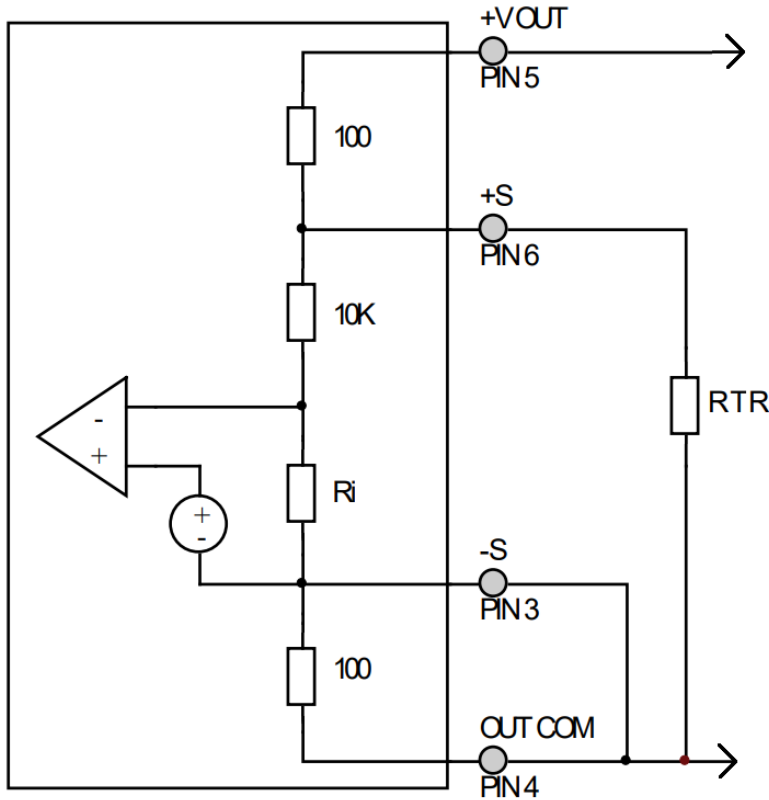

+V _{OUT} (V)	R _{TR} (Ω)
5.70	1.09k
5.65	1.22k
5.60	1.39k
5.55	1.60k
5.50	1.89k
5.45	2.31k
5.40	2.97k
5.35	4.16k
5.30	6.93k
5.25	20.8k
5.20	-

JETPT40-P3-V2 (DVTR285R2S)

Dimensions - JETPT40-27WS5.2-P3 (DVTR285R2S)

1	2	3	4	5	6	7	8	9	10
28VIN	INHIBIT	-S	OUTCOM	+VOUT	+S	CASE	CASE	not use	INCOM

Dimensions in millimeters, PCB mounting only, tolerance ± 0.1 mm unless stated otherwise.

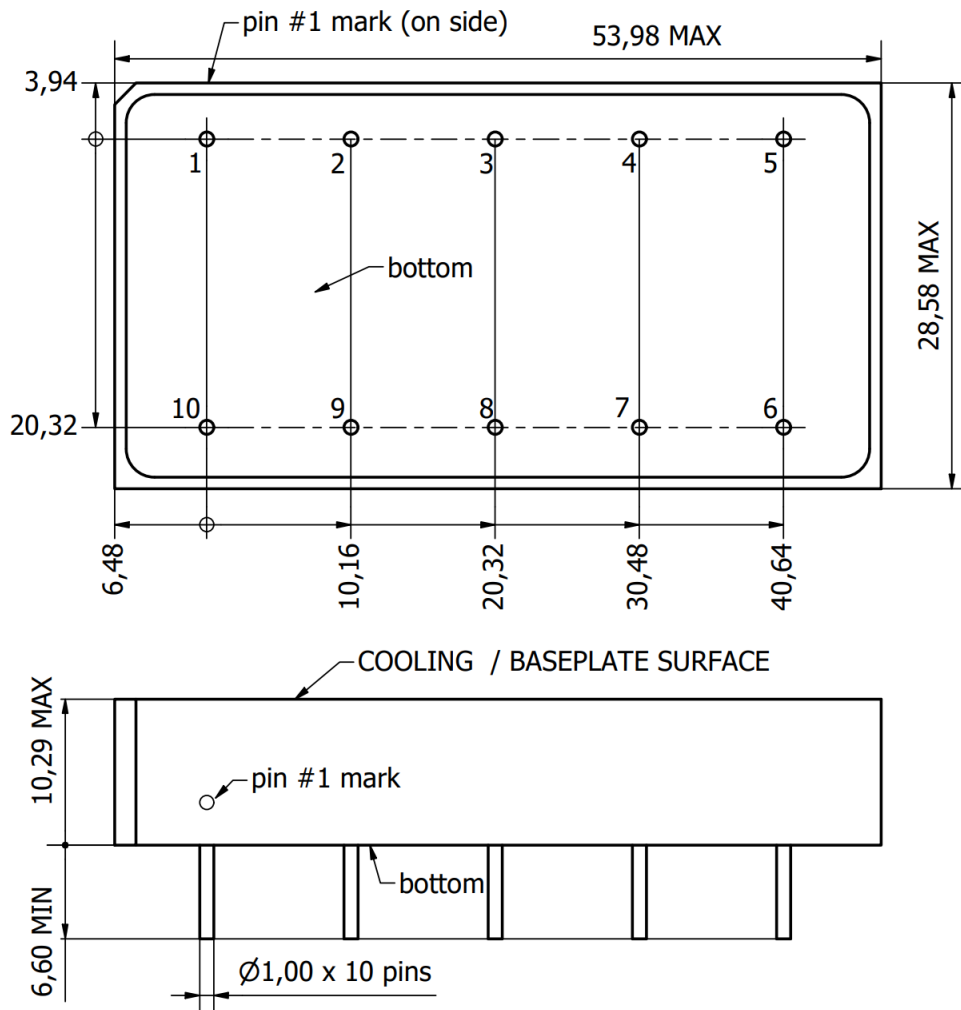

JETPT40-P3-V2 (DVTR285R2S)

Additional information

After ordering the product - the customer is fully responsible for applying the product in strict compliance with mentioned rules and principles of use in the product datasheet and reference technical material (RTM) which is downloadable at www.aeps-group.com.

Please, note that all information in this material is for reference only. Further detailed information (including: additional requirements, manuals and circuit schemes, etc.) is found at www.aeps-group.com or provided via an email request at aeps@aeps-group.cz. All pictures shown are for illustration purpose only, actual product appearance may vary, incl. inner components choice and placement and connectors placement.

According to company's policy in view of constant improvements of the production design the manufacturer reserves the right to change the contents of specifications and promotional materials without prior notice! Make sure you are using the latest documentation downloadable at www.aeps-group.com.

© «AEPS-GROUP». All rights reserved.